

### Application

- Cordless Telephone / Facsimile

### Features

- Dimensions (12.30×4.70×3.50)
- Resistance Sealed
- SMD Lower Height Design
- Metal Standard Package
- Tight Tolerance and Stability



### Specifications



Model	KLS14-HC-49SMD	
Nominal frequency range	3.500~40.000 MHz	30.000~80.000 MHz
Crystal cut	Fundamental [AT-cut]	3rd overtone [AT-cut]
Storage temperature range	-40°C~+85°C	
Operating temperature range	-20°C~+70°C, -40°C~+85°C	
Frequency temperature characteristics (Ref. to +25°C)	±50×10 <sup>-6</sup>	
Frequency tolerance (at +25°C)	±30×10 <sup>-6</sup>	
Equivalent series resistance	Please Refer to the Following ESR Table	
Load capacitance	series, 16pF, 20pF, 30pF	
Shunt capacitance	5pF max.	
Level of drive	10μ W (100μ W max.)	

Package quantity: 1,000pcs /Reel

Frequency	ESR(Ω)
Fundamental	
3.500~ 3.999	150
4.000~ 4.999	120
5.000~ 5.999	100
6.000~ 8.999	80
9.000~ 9.999	60
10.000~12.999	50
13.000~18.999	40
19.000~40.000	30
3rd overtone	
30.000~44.999	80
45.000~59.999	70
60.000~80.000	60

### Outline and Dimensions [unit:mm]

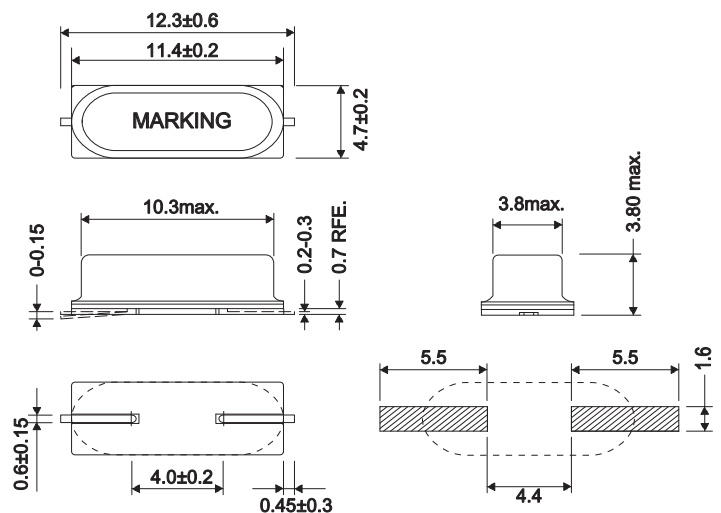

### ORDER INFORMATION

L-KLS14-HC-49SMD-XXXX-XX-XX-X

